



TRANSPONDER INSTALLATION INSTRUCTIONS

NY E-ZPass License Plate

The FME transponder is recommended for trucks, buses, coaches, RVs, and other classes of large commercial vehicles. FME transponders are programmed for license plate mount on the front of the vehicle only.



E-ZPASS COVERAGE

Delaware	Kentucky	New Hampshire	Pennsylvania
Florida	Maine	New Jersey	Rhode Island
Illinois	Maryland	New York	Virginia
Indiana	Massachusetts	North Carolina	West Virginia
	Minnesota	Ohio	

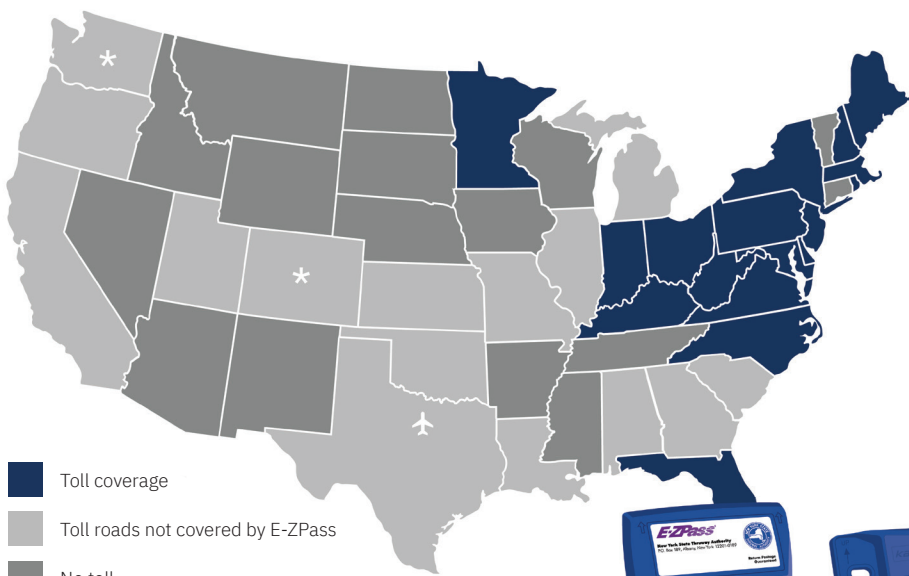

- Toll coverage
- Toll roads not covered by E-ZPass
- No toll
- ✳ Toll by plate coverage in CO and WA
- ✈ Our transponder and toll by plate solution do not cover DFW Airport in Dallas



E-ZPass Windshield Transponder
4.6" x 2.9" x 1.25"



E-ZPass Roof Mount Transponder
8.5" x 1.75" x 1"



E-ZPass License Plate Mount
8.5" x 1.75" x 1"

REQUIREMENTS

- For reliable operation of the transponder, the vehicle must be equipped with only one correctly mounted transponder while passing through a toll facility. Other transponders present in or on the vehicle must be switched off or enclosed in an RF shield.
- FME transponders must be mounted in the location for which they were programmed. FME transponders programmed for license plates must be mounted on the front of the vehicle.
- The mounting location must provide direct line-of-sight communication between the transponder and the toll facility's overhead antenna.
- FME transponders cannot be used where local regulations prohibit externally mounting transponders on the front license plate, front bumper, or other external surfaces.
- The presence of certain classes of front impact-absorbing materials used in the construction of the vehicle may affect the operation of the FME transponder. The mounting location must be free of such materials.

FME FRONT MOUNTING INSTRUCTIONS

Select a mounting location either on the front license plate using the license plate mounting screws or on the front of the vehicle using the mounting plate. Consider the following criteria:

- a minimum of 24 inches of clearance of bumper or other large objects that extend 7+ inches (A1).
- a minimum of 15 inches from the top of the transponder to the roadway for front bumper mounting.
- the transponder must be mounted within 4 inches of the vehicle center.

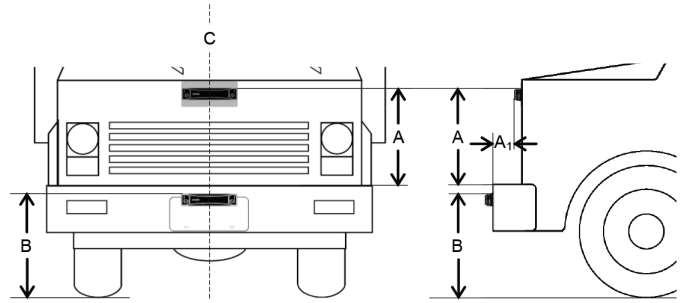

FME Mounted on License Plate

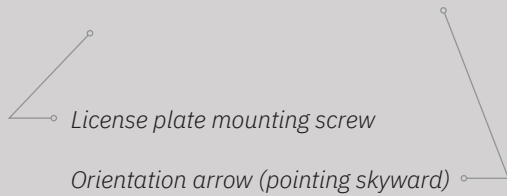

If mounting the transponder on the front license plate:

- Remove the two upper license plate mounting screws securing the license plate to the front of the vehicle.
- Using the license plate mounting screws removed in step 1, secure the transponder, with orientation arrows pointing skyward, and the license plate to the front of the vehicle.

If mounting the transponder elsewhere on the front of the vehicle:

- The back of the mounting plate is covered with 3M VHB acrylic foam tape. Prepare the mounting location in accordance with 3M document 70-0704-8701-5.

NOTE: ensure the mounting plate is installed on the vehicle so that when the transponder is installed on the mounting plate, the orientation arrows on the transponder point skyward.

- Remove the protective paper from the adhesive on the back of the mounting plate and firmly press the mounting plate against the mounting surface with either a roller or platen pressure, maintaining pressure for 15 seconds to ensure a good bond.
- Using the supplied tamper-proof nuts, lock washers, and flat washers, secure the transponder to the mounting plate with the notches on the transponder and mounting plate aligned and with the orientation arrows on the transponder pointing skyward.

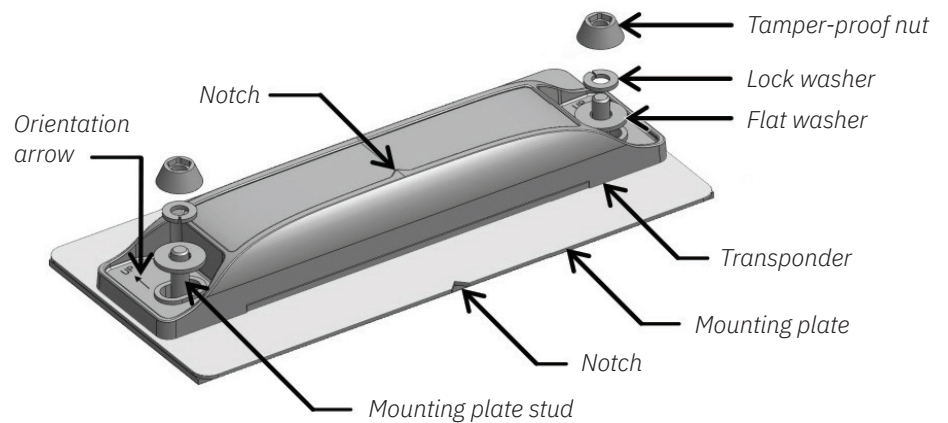

For additional support, contact Bestpass at 888.410.9696 or support@bestpass.com.

FME on Mounting Plate